

Opera-SH

Jackshaft Operators
Heavy-Duty Industrial Hoist

Standard Features

■ Motor

60Hz high starting torque, continuous-duty, single-phase capacitor start or 3-phase motor, open drip proof, protected against overload. Also available with 50Hz 220V 1-phase and 380V 3-phase motor, consult inside sales.

■ Reduction

First step in reduction 5L/B V-belt drive, additional steps by chain and sprockets. Input shaft is 3/4", supported by cast iron flanged pillow block bearings. Output shaft is 1" with 1/4" keyway, supported by cast iron flanged pillow block bearings. Output shaft speed: 41 rpm.

■ Clutch

Friction type, positioned on input shaft, easily adjustable from outside.

■ Drive

#50 roller chain with a 50B12 sprocket for the operator drive shaft. Door sprocket selected for a door travel of 6"/s to 12"/s.

■ Brake

Electrically activated drum-band type solenoid brake.

■ Manual Operation

Emergency manual chain hoist. ⁽¹⁾ Floor level chain hoist engaging device with electrical cut-out. An electrical interlock automatically disconnects power to the motor operator when chain hoist is engaged. Hoist on right is standard.

■ Electrical Enclosure

All electrical components are in a Nema 1 enclosure. Hinged electrical enclosure cover with stable opened position.

■ Limit System

Rotary-type oil-impregnated steel cams, commercial grade switches. Limit shaft is supported by self-lubricating bronze bushings for increased precision. Remains in time when there is a manual operation or after the motor has been removed.

■ Accu-cam® Feature

Precise and quick one-handed adjustment of the limits.

■ Corrosion Protection

Frame and control enclosure protected by baked on, long lasting enamel finish. Polymer control box cover. All shafts protected by yellow chromate coating.

■ Mounting

Wall, hood, or shelf mounted on the right or on the left of the door. For indoor use only.

■ Shipping Weight

Approx. 96 lb - 44 kg.

■ Warranty

2 Years.

Cast Iron Pillow Block Bearings

Flanged pillow block bearings on the input and output shafts

Solenoid Brake

Drum-band type solenoid brake

Accu-cam® Limit Feature

For precise and quick one-hand limit setting adjustments

Emergency Manual Chain Hoist

With floor level chain hoist engaging device and electrical cut-out

Hinged Cover with Stable Opened Position

For easy access to components and wiring



The Opera-SH fills the gap between regular jackshaft and gearhead operators. This is an ultra high-end heavy-duty V-belt drive industrial operator designed for use on standard, high and vertical lift sectional doors or rolling doors and grilles.

The operator can be wall, hood, or shelf mounted on either side of the door. It incorporates a solenoid brake and a chain hoist for manual operation, with a floor level engaging device.

The operator is offered with the Electronic Control Board (BOARD 070) and monitored external entrapment protection devices (ANSI/CAN/UL 325 compliant).

⁽¹⁾ The hoist is designed for light and limited use in the event of troubleshooting only.

Control Options

■ ECB Units (BOARD 070)

24Vdc relaying circuit with a 40VA class II transformer, non-volatile memory. Features available: On-board radio receiver, 1.5s delay on reverse, programmable maximum run timer, mid-stop, timer to close (suspension possible from floor level), built-in cycle-counter, independent input loop terminal, advance close system, test buttons, reverse wiring detection and door lock sensor. Operating mode selectable on site: C2, B2, D1, E2, T or TS.

■ "M" Version



Provides the monitoring of Primary External Entrapment Protection Devices. Includes monitored photoelectric cells (PHOTO 070 standard). In this mode, Ancillary Entrapment Protection Devices (optional) may be used to supplement primary entrapment protection, such as non-monitored photoelectric cells, 2-wire non-monitored sensing edges and pneumatic sensing edges. Certifications: ANSI/CAN/UL 325.

Note: ANSI/CAN/UL 325 apply to units intended to be used in ordinary locations in accordance with the Canadian Electrical Code, Part I and the National Electrical Code, NFPA 70, respectively.

Main Options

■ Control Accessories

Angled terminal strip allows for the connection of 3-button stations (one supplied with the operator), non-monitored sensing edges / photoelectric cells / light curtains, external radio receiver, ceiling pull switches, key switches, loop detectors, LED strips, external interlocks, universal auxiliary output module. Optional Manaras Internet Control™ (MIC) available. 2A fuse protected 24VAC output is available for accessory power supply. Nema 4/12 or Nema 4X protected monitored photo cells upgrade available.

■ Environmental Modifications

Nema 4/12 and Nema 4X enclosures. For Nema 7/9, consult inside sales.

■ Mechanical Accessories

Wall or hood mounting bracket, chain spreader, etc. Consult inside sales.

■ Mechanical Modifications

Left hand chain hoist, limit shaft speed-up, cogged v-belt, etc. Consult inside sales.

Dimensions

Clearance: Side room required 16" (460 mm)

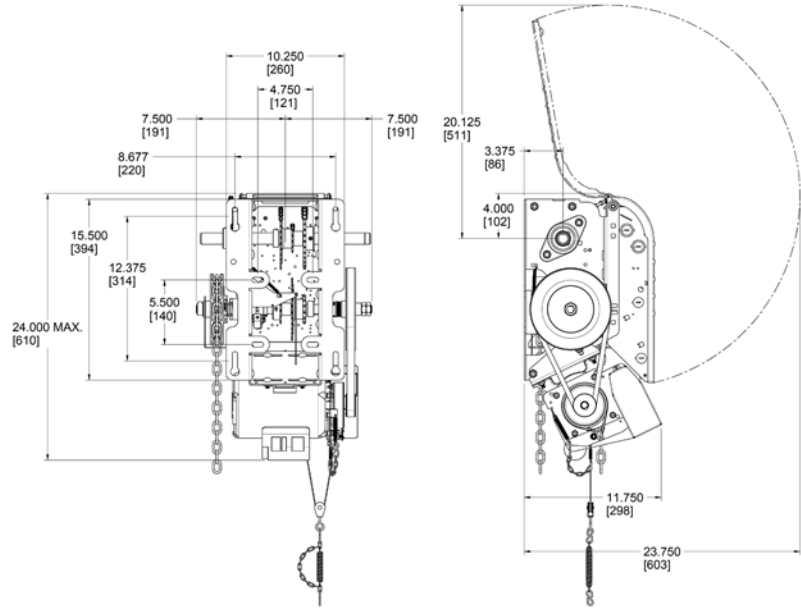

Motor Selection

Maximum Door Area in Square Feet (WxH)

Horse Power	Rolling Doors					Sectional Doors				
	Insulated Steel	16 ga. Steel	Steel Grilles 20 ga. Steel	Aluminum 22 ga. Steel	Aluminum Grilles 24 ga. Steel	18 ga. Insulated Steel	18 ga. Steel/ 20 ga. Insulated Steel	Wood 20 ga. Steel/ 22 & 24 ga. ins. Steel	Aluminum 22 & 24 ga. Steel	Fiberglass
1/2	157	236	260	319	358	196	245	314	343	392
3/4	206	294	358	451	515	270	319	441	490	549
1	255	358	446	574	613	294	392	490	564	613

General Guideline

Operator Range

Current Consumption (Amp.)

Horse Power	Nominal Voltage (V) / Phase				
	120V / 1 Ph	240V / 1 Ph	208V, 240V / 3 Ph	480V / 3 Ph	600V / 3 Ph
1/2	8.0	4.0	2.1	1.0	0.8
3/4	11.2	5.6	3.2	1.5	1.2
1	13.6	6.8	4.4	2.1	1.6

General Guideline

**For more information, please visit
www.devancocanada.com
or call toll free at 1-855-931-3334**

Manaras-Opera reserves the right to make specifications or design changes without prior notice.

©2024 9141-0720 Québec Inc. All rights reserved. Reg. T.M. of 9141-0720 Québec Inc. UL logo is a Reg. T.M. of UL LLC. | CSA logo is a Reg. T.M. of CSA Group.

